

Electrolux concept counters

Refrigerators - 3 compartments

The models shown on this sheet are food preparation and preservation tables. Their versatility allows notable savings in space while offering functional and modular solutions for all types of kitchen requirements.



727162



727163



727164



727168



727169



727170

- Built-in refrigeration unit.
- 150 mm height-adjustable stainless steel feet.
- Internal and external doors, front and side panels and worktop in AISI 304 stainless steel.
- Anti-drip profile on stainless steel worktop edge.
- Easy to clean reversible door with rounded internal corners.
- IP65 digital control panel allows for temperature and parameter setting as well as to activate defrosting when necessary.
- The refrigerated compartment is designed to accommodate GN 1/1 containers on 6 levels.

- Suitable to operate in ambient temperatures up to +43°C. Temperature range: -2/+10 °C.
- Forced air circulation for rapid cooling and an even temperature distribution.
- Completely automatic defrosting and automatic evaporation of defrost water. Drain outlet.
- Access to all components from the front.
- HCFC, CFC and HFC free insulation (Cyclopentane), HCFC and CFC free refrigerant gas (R404a).

- All models comply with the standards required by the main international approval bodies and are CE marked.
- High-density expanded polyurethane insulating foam, 60 mm in thickness, with cyclopentane injection, guarantees exceptional, long-term insulation and notable energy savings.
- Developed and produced in ISO 9001 and ISO 14001 certified factory.

**Electrolux concept counters
Refrigerators - 3 compartments**

HBAC-3

2008-01-21

	HB3PA 727162	HB9CA 727163	HB6CA 727164	HB3PUA 727168	HB9CUA 727169	HB6CUA 727170
TECHNICAL DATA						
Operating temperature - min/max °C	-2/10	-2/10	-2/10	-2/10	-2/10	-2/10
Operating mode	Ventilated	Ventilated	Ventilated	Ventilated	Ventilated	Ventilated
Gross capacity (D.I.N. 8952) - l.	420	420	415	420	420	420
Cooling unit	Built-In	Built-In	Built-In	Built-In	Built-In	Built-In
External dimensions - mm						
width	1718	1718	1718	1718	1718	1718
depth/with open doors	700, 1102	700, 1102	700, 1102	700, 1102	700, 1102	700, 1102
height	850	850	850	950	950	950
Internal dimensions - mm						
depth	580	580	580	580	580	580
height	543	543	543	543	543	543
Top material	Galvanized Steel	Galvanized Steel	Galvanized Steel	Galvanized Steel	Galvanized Steel	Galvanized Steel
Min/Max internal humidity - %	50	50	50	50	50	50
N° of drawers			6x1/2			
Compressor power - HP	1/4	1/4	1/4	1/4	1/4	1/4
N° defrost in 24 hrs.	4/20	4/20	4/20	4/20	4/20	4/20
Refrigerant type	R404a	R404a	R404a	R404a	R404a	R404a
Refrigerant quantity - g.	170	170	170	170	170	170
Refrigerant power - W	343	343	343	343	343	343
Evaporation temperature - °C	-20	-20	-20	-20	-20	-20
Power - kW						
installed-electric	0.34	0.34	0.335	0.34	0.34	0.34
Net weight - kg.	142	142	168	143	143	143
Supply voltage	230 V, 1N, 50	230 V, 1N, 50	230 V, 1N, 50	230 V, 1N, 50	230 V, 1N, 50	230 V, 1N, 50

Subject to change without notice

**Electrolux concept counters
Refrigerators - 3 compartments**

727162, 727168

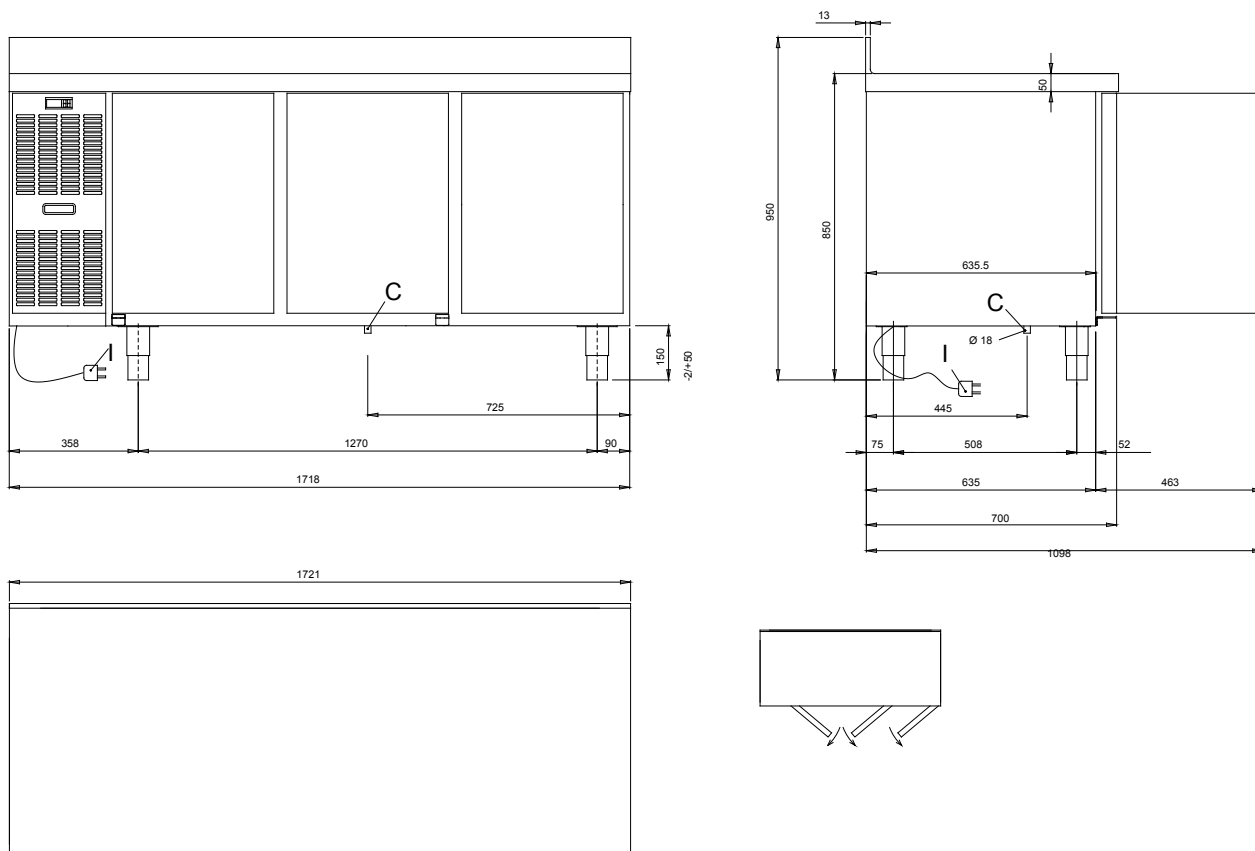

	HB3PA 727162	HB3PUA 727168
LEGEND		
C - Water drain	16mm	16mm
I - Electrical connection	230 V, 1N, 50	230 V, 1N, 50

HBAC-3

2008-01-21

Subject to change without notice

**Electrolux concept counters
Refrigerators - 3 compartments**

727163, 727169

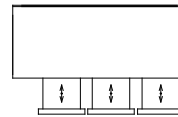
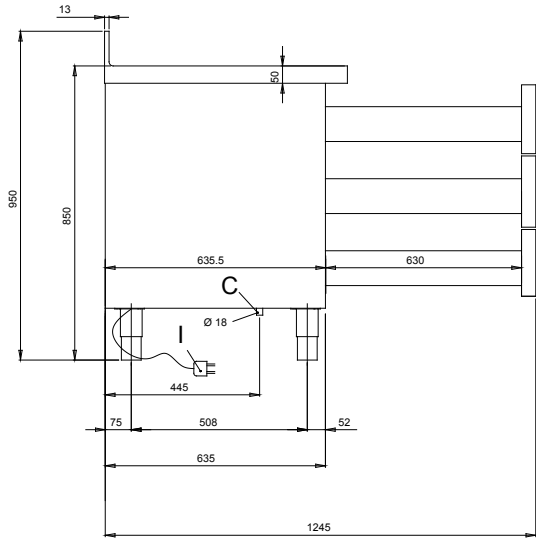
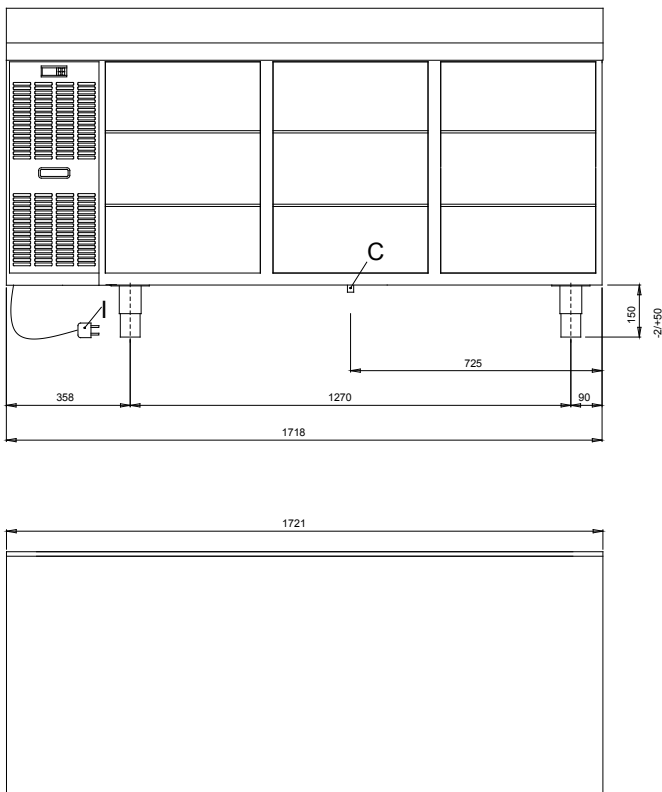

HBAC-3

2008-01-21

	HB9CA 727163	HB9CUA 727169
LEGEND		
C - Water drain	16mm	16mm
I - Electrical connection	230 V, 1N, 50	230 V, 1N, 50

Subject to change without notice

**Electrolux concept counters
Refrigerators - 3 compartments**

727164, 727170

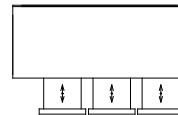
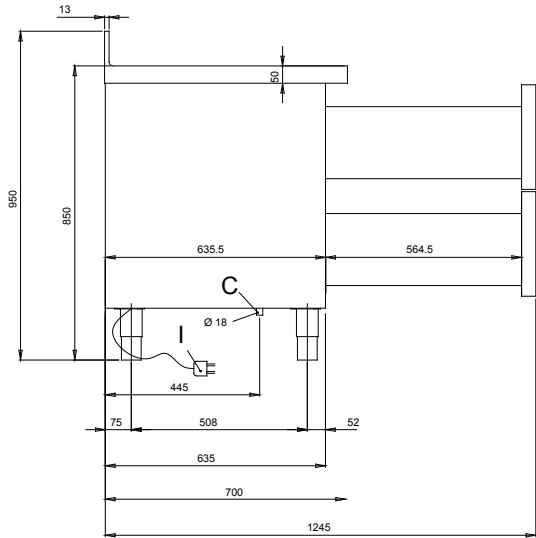
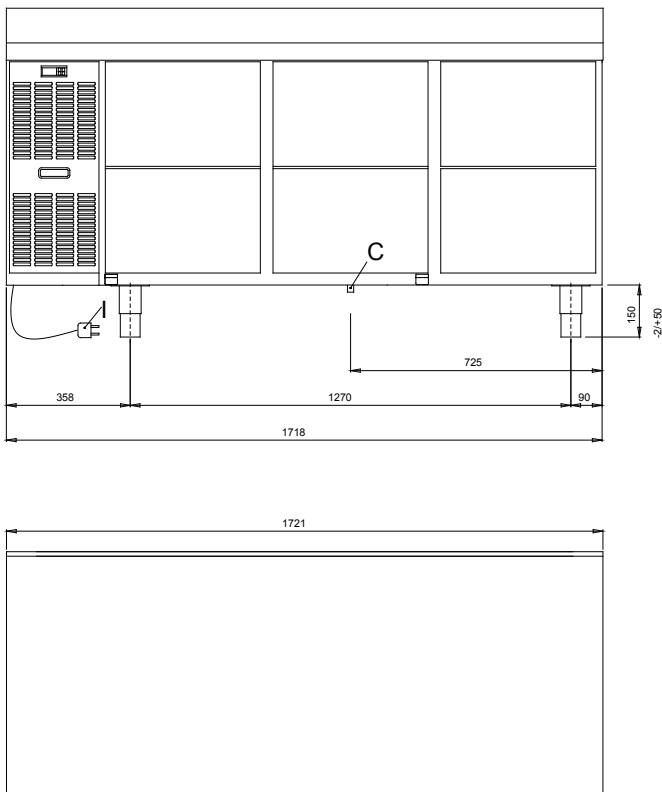

HBAC-3

2008-01-21

	HB6CA 727164	HB6CUA 727170
LEGEND		
C - Water drain	16mm	16mm
I - Electrical connection	230 V, 1N, 50	230 V, 1N, 50

Subject to change without notice