

SCN 215

SIMAG

160 kg Self-contained Ice Cuber

Other models in this range: SCN25 - SCN35 - SCN45 - SCN75 - SCN125

Technical Features

- Stainless steel bodywork - scotch brite
- Air or water cooled
- Vertical pump
- Main switch (ON/OFF)
- Built-in cleaning system
- Easily accessible components
- Low power and water consumption
- Optimum ratio between ice production and bin capacity
- Reduced dimensions
- Double defrosting system
- Refrigerant R404A

24 Hour Ice Production - 10°C/10°C

Air cooled 160 kg - N° of cubes 8000
Water cooled -

Bin capacity

kg 68

Warranty

3 years warranty on components

Voltage

230/50/1 standard version
220-240/60/1 version available on demand

Technology and Certifications



Certified ISO 9001

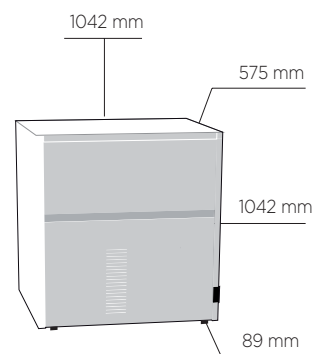
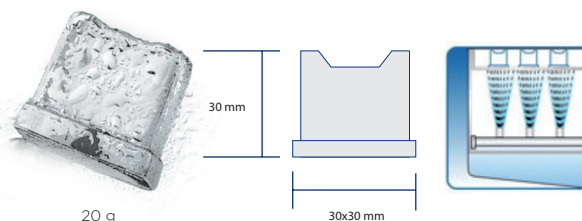

MILANO OFFICE
Sales Dept.
Tel. +39 02 93900215
e-mail: sales@simag.it
Service Dept.
Tel. +39 02 93960357
e-mail: service@simag.it

SIMAG FAR EAST
Singapore Office
Tel. ++65 6738 5393
e-mail: scotsman@scotsman.com.sg

www.simag.it

SCN 215



160 kg Self-contained Ice Cuber

Other models in this range: SCN25 - SCN35 - SCN45 - SCN75 - SCN125

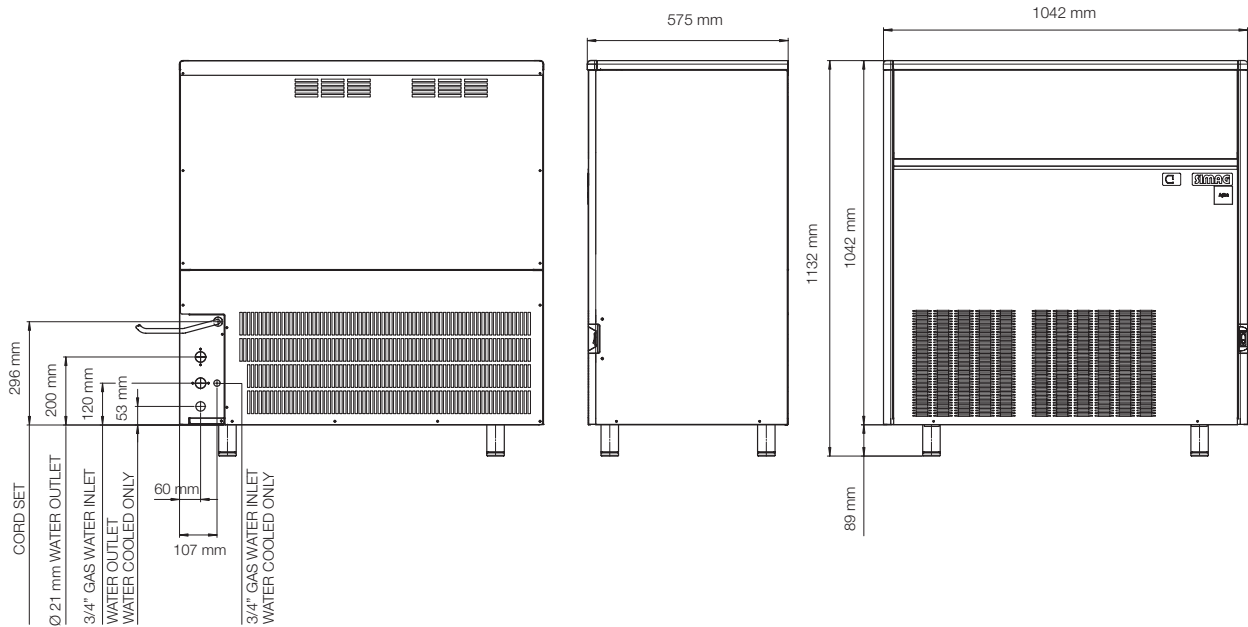

* DRAINAGE PER GRAVITY



CONTROL BOARD



CLEANING SYSTEM

Easy cleaning of water pump filter



MAIN SWITCH

New embedded main switch



TOP ANGLE

New top plastic round corners



VENTILATING GRILLE

New ventilating grille in water cooled version



AIR FILTER

New condenser air filter for air cooled version

Operating Limits

	Minimum	Maximum
Air Temperatures	10°C	43°C
Water Temperatures	5°C	38°C
Electrical Voltage	-10%	+10%
Water Pressure	14 psi 1 bar	70 psi 5 bar

Specifications and design are subject to change without notice

Model	Voltage	Power input Watt (*)	Refrigerant type	Refrigerant charge kg	Fuse AMP	Water consumption l/h (**)	Net weight kg	Shipping weight kg
SCN 215 AS	230/50/1	1750	R404A	0.66	20	21	131	148
SCN 215 AS	220-240/60/1	1750	R404A	0.66	20	21	131	148

(*) Power Input: at 43°C Ambient Temperature
 (**) Water Consumption: at 32°C Air and 21°C Water